

RGBW DMX512 Controller

09.34WDU.04713



Important: Read All Instructions Prior to Installation

Function introduction

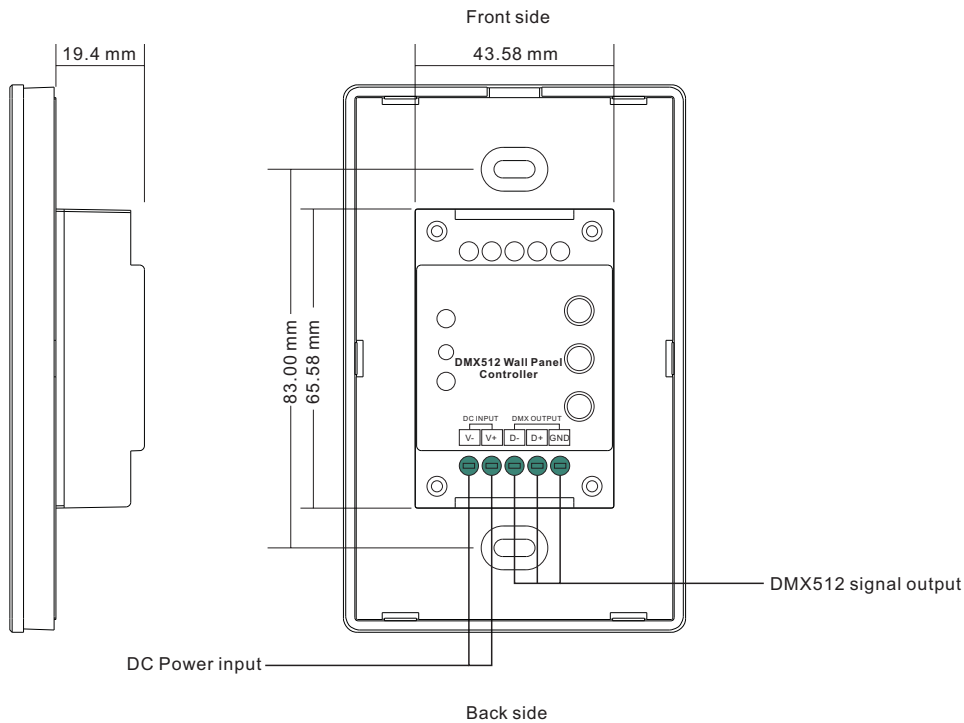
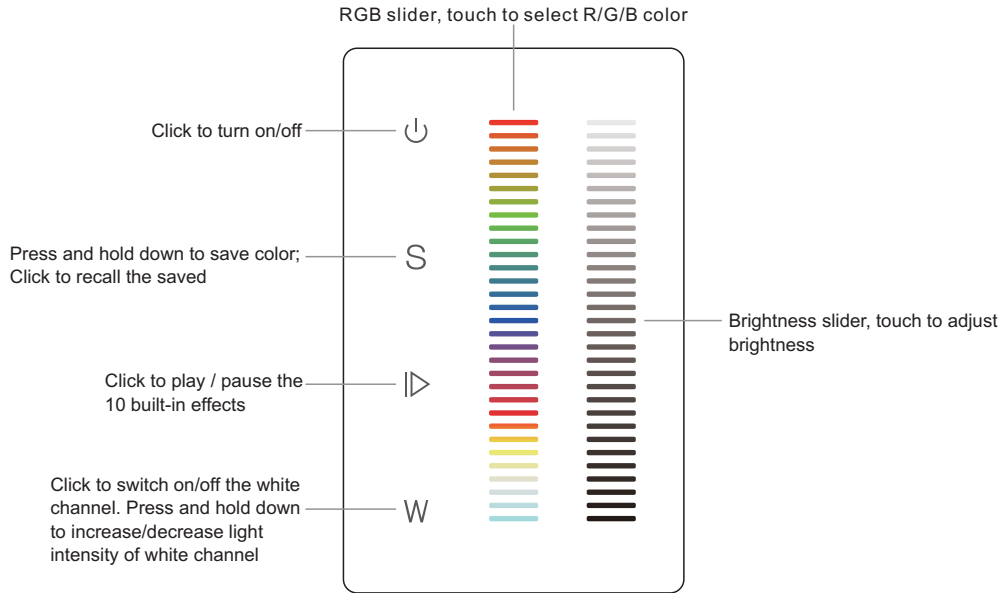

Product Data

Output Signal	DMX512 signal
Power Supply	12-24VDC
Power consumption	200 mA
Operating temperature	0-40°C
Relative humidity	8% to 80%
Dimensions	75x120x29.1mm

- Touch sensitive
- Glass interface(white & black)
- Standard DMX512 Signal output
- Control RGBW color
- Control 1 zone
- Waterproof grade: IP20

Safety & Warnings

- DO NOT install with power applied to device.
- DO NOT expose the device to moisture.

Wiring diagram

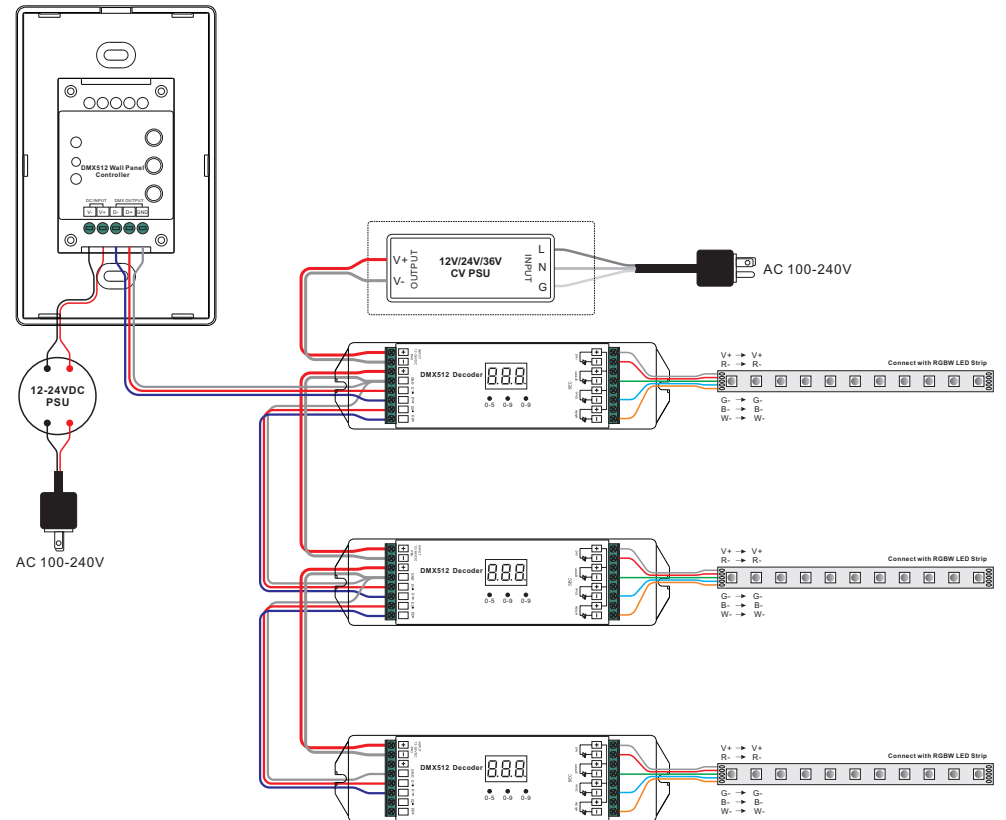

Set DMX Address

This DMX master controller can control many DMX decoders, please set all decoders' address as 001.

Installation

